

Customer drawings
Reference only

REV.	ECN.NO.	MODIFY.CONTENT	DATE

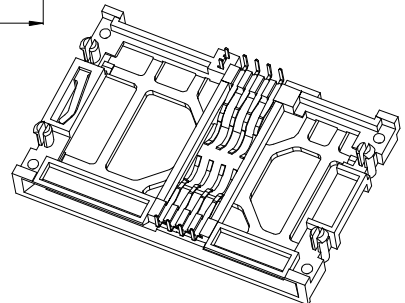
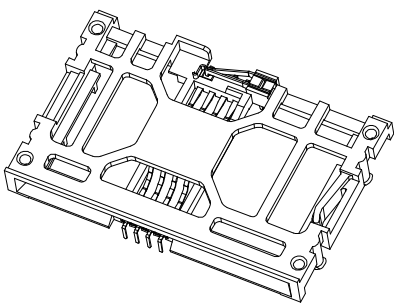
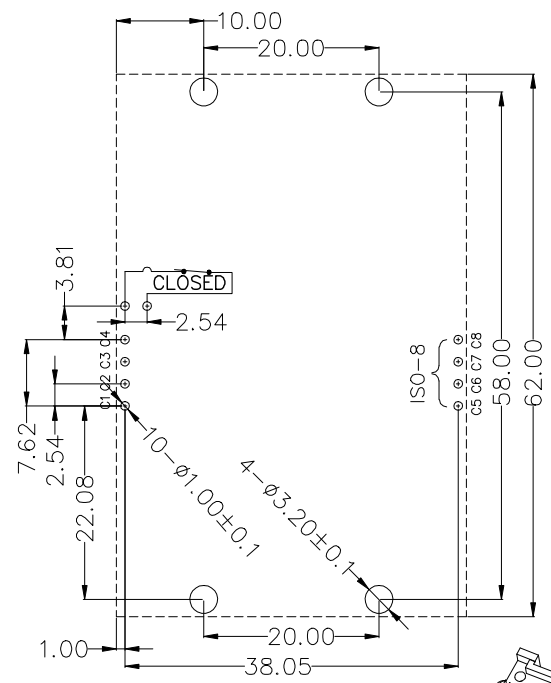
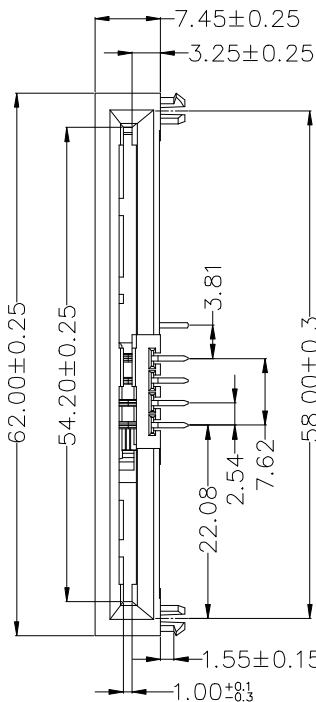
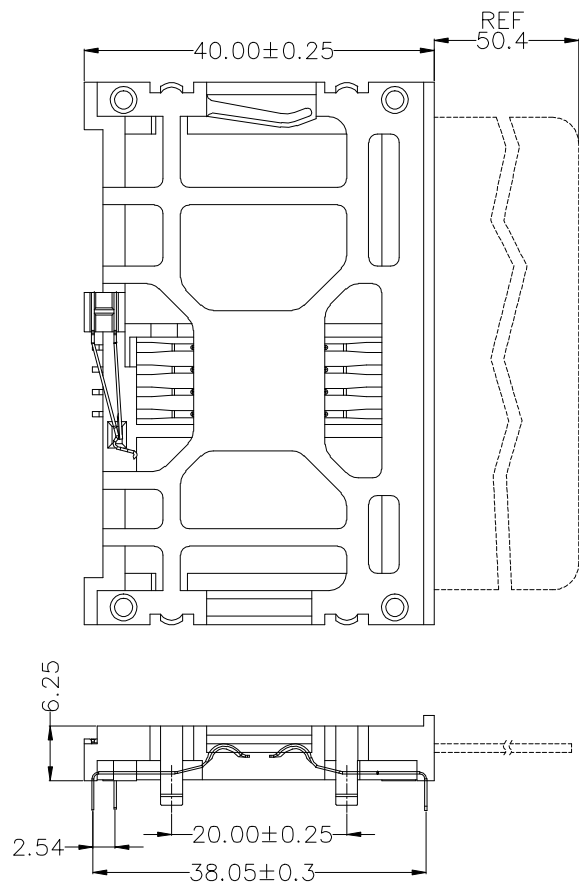

TECHNICAL CHARACTERISTICS

1.General Characteristics

Dimensions: 62.0LX40.0Wx11.0H mm
Weight: Approx 7.65±0.5g
Durability: 100,000 cycles min.

2.Electrical Characteristics

Contact resistance: 50mΩ typical, 100mΩ max
Insulation resistance: >1000MΩ/500V DC

3.Solderability

Manual soldering: 370°C, 3sec.Max

4.Environmental Characteristics

Operating temperature: -40°C~+85°C

ELECTRIC FUNCTION	DETECT SWITCH
WITHOUT CARD	CLOSED
CARD INSERTED	OPEN

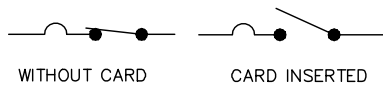

SWITCH OPERATION DIAGRAM

ITEM	PART NAME	Q'TY	MATERIAL	FINISH
1	BASE	1	Thermoplastic	Black UL94V-0
2	DATA CONTACT 1	8	Copper Alloy	Contact area:Gold plated
3	SWITCH CONTACT 1	1	Copper Alloy	Contact area:Gold plated
4	SWITCH CONTACT 2	1	Copper Alloy	Contact area:Gold plated

GENERAL TOLERANCE		图号	设计	彭善平	比例	1:1	
X.±0.30	x.'±5'	品名	IC Card Acceptor 无垫高型	审核	Raliny.xu	单位	mm
.X±0.25	.x'±2'			核准	WANG	视角	45°
.XX±0.15	.xx'±1'			日期	2017/10/14	版本	A0
.XXX±0.10	.xxx'±0.5'						
页数	1/1						

Customer drawings
Reference only

REV.	ECN.NO.	MODIFY.CONTENT	DATE

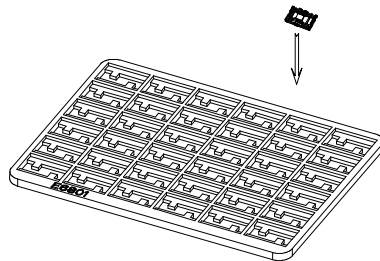

DIA. :43L*31W*1.4cm
N.W. :0.62KGS
G.W. :0.70KGS
Q'TY :36 PCS

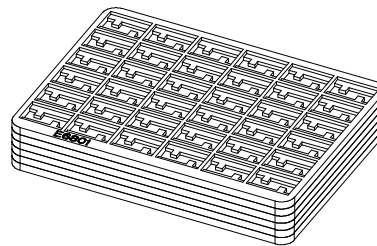

DIA. :45L*33W*8.8cm
N.W. :2.00KGS
G.W. :2.20KGS
Q'TY :216 PCS

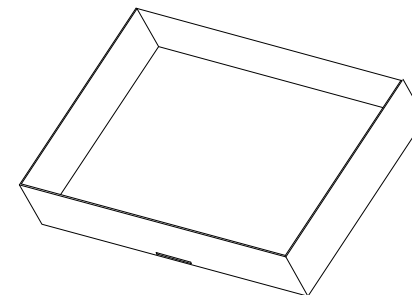
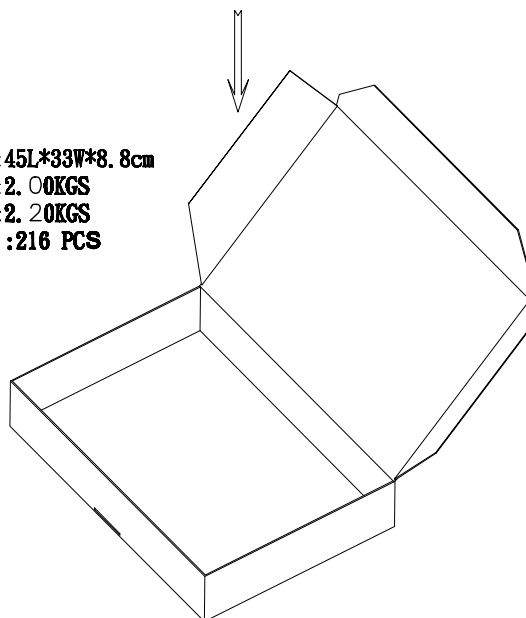

DIA. :48L*35W*46cm
N.W. :10.5KGS
G.W. :11.0KGS
Q'TY :1080 PCS

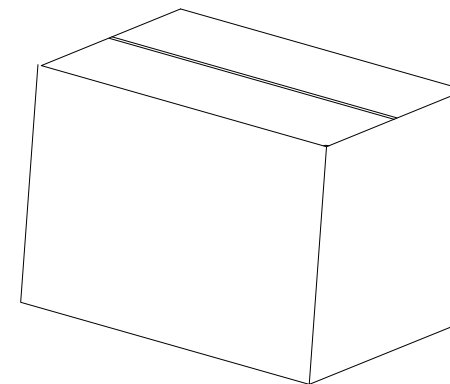

- 1.成品置於吸塑盤中,金屬零件以不接觸吸塑盤為原則.
- 2.每一盤放36pcs成品後,以累積6盤再放一內盒.1內盒裝216個成品.
- 3.Reel之Label一致朝上.
- 4.先置入一瓦楞紙板於紙箱底部.
- 5.將內盒置於箱內→封口→置於箱中(一箱裝5個內盒).一箱1080PCS.
- 6.以Tape封合,並貼上成品包裝標籤.

GENERAL TOLERANCE		图号	设计	彭善平	比例	1:1	
X.±0.30	x.'±5'	品名	IC Card Acceptor 无垫高型	審核	Raliny.xu	单位	mm
.X±0.25	.x'±2'			核准	WANG	视角	
.XX±0.15	.xx'±1'	料号	日期	2017/10/14	版本	A0	
.XXX±0.10	.xxx'±0.5'						
页数	1/1						